



Antennas

DATA SHEET

Hybrid Bi-Sector™ Array

16HBSAR-BWW7NA

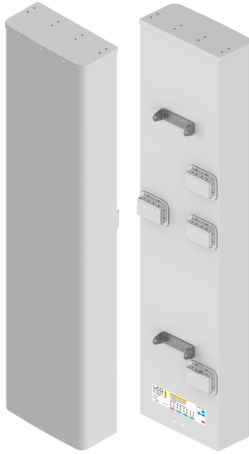

- Seven foot (2.1 m) and 19.6" (498 mm) wide, multiband, Sixteen port Hybrid Bi-Sector™ Antenna. Deploying a high performing 65° azimuth beamwidth covering 698-896 MHz and 1695-2180 MHz and a pair of CCI's Patented Asymmetrical 33° Shaped Beams covering 1695-2180 MHz frequencies
- Four wide Mid Band ports covering 1695-2180 MHz, eight Bi-Sector™ wide Mid Band ports covering 1695-2180 MHz and four wide Low Band ports covering 698-896 MHz in a single antenna
- Full Spectrum Compliance for 698-896 MHz /1695-2180 MHz
- Provides a pair of LTE Optimized Asymmetric Shaped Beams for improved LTE data throughput by minimizing beam crossover, providing for an efficient use of valuable radio capacity and frequency spectrum
- LTE Optimized FBR, SPR and Boresight/Sector XPD Performance, essential for today's LTE Data Networks
- Exceeds minimum PIM performance requirements
- Equipped with new 4.3-10 connector, which is 40% smaller than traditional 7/16 DIN connector
- Equipped with Four Field Replaceable, integrated AISG 2.0 compliant Remote Electrical Tilt (RET)

Overview

This version of the CCI Hybrid Bi-Sector™ Multiband Array is a Sixteen port antenna, four wide Mid Band ports covering 1695-2180 MHz, eight Bi-Sector™ wide Mid Band ports covering 1695-2180 MHz and four wide Low Band ports covering 698-896 MHz in a single antenna. The CCI Hybrid Bi-Sector™ array uses a pair of CCI's Patented Asymmetric 33° Shaped Beams in the Mid Band frequencies and a dedicated high performance 65° azimuth beamwidth in the Low Band and Mid Band frequencies. The CCI Hybrid Bi-Sector™ Array thus provides the capability to deploy Dual (over split beams) 4x4 Multiple-input Multiple-output (MIMO) in the Split Beam array and Single 4x4 Multiple-input Multiple-output in the Low Band and Mid Band 65° arrays. The CCI Hybrid Bi-Sector™ Array utilizes four Type 17 RET controllers, with a separate RET control for the Low Band and Mid Band 65° arrays and a separate RET control in the Split Beam Mid Band array for each LEFT and RIGHT pair of CCI's Patented Asymmetric 33° Shaped Beams.

The CCI Hybrid Bi-Sector™ Multiband Array, will allow operators to reduce antenna count and replace existing 65° networks, while increasing cell site capacity and LTE data throughput by minimizing overlap between CCI's Patented Asymmetric 33° Shaped Beams. This design approach lowers interference between sectors. All of this is achieved through a single panel array, producing significant CAPEX and OPEX cost savings for the operator.

CCI antennas are designed and produced to ISO 9001 certification standards for reliability and quality in our state-of-the-art manufacturing facilities.

Applications

- Dual (over split beams) 4x4 MIMO on Split Beam Mid Band Array and single 4x4 MIMO on Low Band and Mid Band 65° Arrays
- Ready for Network Standardization on 4.3-10 connectors
- Ideal Antenna Solution for structurally constrained sites, where data throughput, capacity and limited spectrum is a concern
- With CCI's Hybrid Bi-Sector™ Antenna, wireless operators can connect multiple platforms to a single antenna, reducing tower load, lease expense, deployment time and installation cost



Antennas

SPECIFICATIONS

Hybrid Bi-Sector™ Array

16HBSAR-BWW7NA

Electrical

Ports	4 × Low Band Ports for 698-896 MHz	
Frequency Range	698-806 MHz	824-896 MHz
Gain ¹	14.5 dBi	15.6 dBi
Azimuth Beamwidth (-3dB)	70°	60°
Elevation Beamwidth (-3dB)	11.1°	9.3°
Electrical Downtilt	2° to 12°	2° to 12°
Elevation Sidelobes (1st Upper)	< -15 dB	< -18 dB
Front-to-Back Ratio @180°	> 28 dB	> 33 dB
Cross-Polar Discrimination (at Peak)	> 25 dB	> 25 dB
Cross-Polar Port-to-Port Isolation	> 25 dB	> 25 dB
Voltage Standing Wave Ratio(VSWR)	< 1.5:1	< 1.5:1
Passive Intermodulation (2x20W)	≤ -153 dBc	≤ -153 dBc
Input Power Continuous Wave (CW)	500 watts	500 watts
Polarization	Dual Pol 45°	Dual Pol 45°
Input Impedance	50 ohms	50 ohms
Lightning Protection	DC Ground	DC Ground

¹Peak gain across sub-bands.

BASTA Electrical Specifications	698-806 MHz	824-896 MHz
Frequency Range	698-806 MHz	824-896 MHz
Gain over all Tilts (dBi)	13.6	14.6
Gain over all Tilts Tolerance (dB)	0.7	0.8
Gain at Low-Tilt (dBi)	13.7	14.7
Gain at Mid-Tilt (dBi)	13.7	14.7
Gain at High-Tilt (dBi)	13.4	14.4
Azimuth Beamwidth Tolerance (°)	10.9	8.1
Elevation Beamwidth Tolerance (°)	1.1	0.6
Electrical Downtilt Deviation (°)	1.1	0.7
First Upper Sidelobe Suppression (dB)	12.6	16.7
Upper Sidelobe Suppression Peak to 20° (dB)	15.7	17.6
Front-to-Back Ratio over ±20° (dB)	20.6	22.6
Cross-polar Discrimination at ±60° (dB)	8.4	7.2

* Electrical specifications follow document "Recommendation on Base Station Antenna Standards" (BASTA) V11.1. All specifications are subject to change without notice.



Antennas

SPECIFICATIONS

Hybrid Bi-Sector™ Array

16HBSAR-BWW7NA

Electrical

Ports	4 × Mid Band Ports for 1695-2180 MHz		
	1850-1990 MHz	1695-1775 MHz	2110-2180 MHz
Frequency Range	1850-1990 MHz	1695-1775 MHz	2110-2180 MHz
Gain ¹	15.5 dBi	15.6 dBi	16.0 dBi
Azimuth Beamwidth (-3dB)	67°	67°	66°
Elevation Beamwidth (-3dB)	7.6°	9.0°	6.8°
Electrical Downtilt	2° to 10°	2° to 10°	2° to 10°
Elevation Sidelobes (1st Upper)	< -18 dB	< -18 dB	< -18 dB
Front-to-Back Ratio @180°	> 35 dB	> 35 dB	> 35 dB
Cross-Polar Discrimination (at Peak)	> 22 dB	> 19 dB	> 22 dB
Cross-Polar Port-to-Port Isolation	> 25 dB	> 25 dB	> 25 dB
Voltage Standing Wave Ratio(VSWR)	< 1.5:1	< 1.5:1	< 1.5:1
Passive Intermodulation (2x20W)	≤ -153 dBc	≤ -153 dBc	≤ -153 dBc
Input Power Continuous Wave (CW)	300 watts	300 watts	300 watts
Polarization	Dual Pol 45°	Dual Pol 45°	Dual Pol 45°
Input Impedance	50 ohms	50 ohms	50 ohms
Lightning Protection	DC Ground	DC Ground	DC Ground

¹Peak gain across sub-bands.

BASTA Electrical Specifications			
Frequency Range	1850-1990 MHz	1695-1775 MHz	2110-2180 MHz
Gain over all Tilts (dBi)	14.5	15.0	15.3
Gain over all Tilts Tolerance (dB)	0.7	0.4	0.7
Gain at Low-Tilt (dBi)	14.0	14.8	15.0
Gain at Mid-Tilt (dBi)	14.6	15.0	15.4
Gain at High-Tilt (dBi)	15.0	15.2	15.3
Azimuth Beamwidth Tolerance (°)	8.6	3.9	5.3
Elevation Beamwidth Tolerance (°)	0.8	0.5	0.4
Electrical Downtilt Deviation (°)	0.7	0.5	0.5
First Upper Sidelobe Suppression (dB)	15.3	15.6	13.1
Upper Sidelobe Suppression Peak to 20° (dB)	16.3	17.5	12.9
Front-to-Back Ratio over ±20° (dB)	26.0	25.5	27.6
Cross-polar Discrimination at 3 dB (dB)	9.3	9.1	7.2

* Electrical specifications follow document "Recommendation on Base Station Antenna Standards" (BASTA) V11.1. All specifications are subject to change without notice.



Antennas

SPECIFICATIONS

Hybrid Bi-Sector™ Array

16HBSAR-BWW7NA

Electrical

Ports	8 × Mid Band Ports for 1695-2180 MHz		
	1850-1990 MHz	1695-1755 MHz	2110-2180 MHz
Frequency Range	1850-1990 MHz	1695-1755 MHz	2110-2180 MHz
Gain ¹	17.2 dBi	16.5 dBi	17.7 dBi
Azimuth Beamwidth (-3dB)	34°	36°	31°
Elevation Beamwidth (-3dB)	8.9°	10.3°	8.0°
Electrical Downtilt	2° to 10°	2° to 10°	2° to 10°
Elevation Sidelobes (1st Upper)	< -17 dB	< -17 dB	< -16 dB
Front-to-Back Ratio @180°	> 35 dB	> 35 dB	> 35 dB
Cross-Polar Discrimination (at Peak)	> 23 dB	> 25 dB	> 25 dB
Cross-Polar Port-to-Port Isolation	> 25 dB	> 25 dB	> 25 dB
Voltage Standing Wave Ratio(VSWR)	< 1.5:1	< 1.5:1	< 1.5:1
Passive Intermodulation (2x20W)	≤ -153 dBc	≤ -153 dBc	≤ -153 dBc
Input Power Continuous Wave (CW)	300 watts	300 watts	300 watts
Polarization	Dual Pol 45°	Dual Pol 45°	Dual Pol 45°
Input Impedance	50 ohms	50 ohms	50 ohms
Lightning Protection	DC Ground	DC Ground	DC Ground

¹Peak gain across sub-bands.

BASTA Electrical Specifications			
Frequency Range	1850-1990 MHz	1695-1775 MHz	2110-2180 MHz
Gain over all Tilts (dBi)	16.7	15.8	17.2
Gain over all Tilts Tolerance (dB)	0.4	0.6	0.4
Gain at Low-Tilt (dBi)	16.8	16.0	17.3
Gain at Mid-Tilt (dBi)	16.7	15.7	17.2
Gain at High-Tilt (dBi)	16.5	15.6	17.0
Azimuth Beamwidth Tolerance (°)	2.1	2.3	1.6
Elevation Beamwidth Tolerance (°)	0.5	0.8	0.4
Electrical Downtilt Deviation (°)	0.6	0.9	0.6
First Upper Sidelobe Suppression (dB)	11.5	14.1	11.0
Upper Sidelobe Suppression Peak to 20°(dB)	13.5	16.1	11.2
Front-to-Back Ratio over ±20° (dB)	27.4	25.7	28.0
Cross-polar Discrimination at 3 dB (dB)	13.9	18.4	12.9

* Electrical specifications follow document "Recommendation on Base Station Antenna Standards" (BASTA) V11.1. All specifications are subject to change without notice.



Antennas

SPECIFICATIONS

Hybrid Bi-Sector™ Array

16HBSAR-BWW7NA

Mechanical

Dimensions (LxWxD)	83.5x19.6x9.1 in (2120x499x230 mm)
Survival Wind Speed	> 150 mph (> 241 kph)
Front Wind Load¹	257 lbf @ 100 mph 1144 N @ 161 kph
Side Wind Load¹	80 lbf @ 100 mph 354 N @ 161 kph
Effective Projective Area (EPA), Front¹	10.8 ft ² (1.0 m ²)
Weight *	89.7 lbs (40.7 kg)
RF Connector	16 x 4.3-10 female
Mounting Pole	2 to 5 in (5 to 12 cm)

¹Windload values calculated using CFD analysis
* Weight excludes mounting



Antennas

SPECIFICATIONS

Hybrid Bi-Sector™ Array

16HBSAR-BWW7NA

Mechanical

Bottom View

16HBSAR-BWW7NA

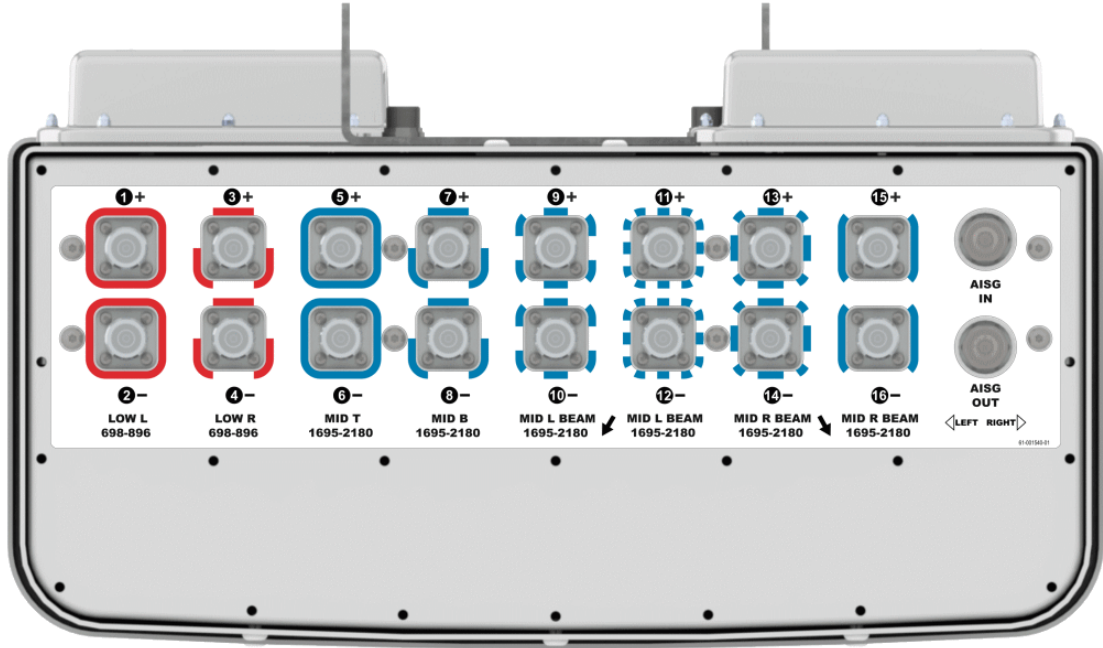

Connector Spacing

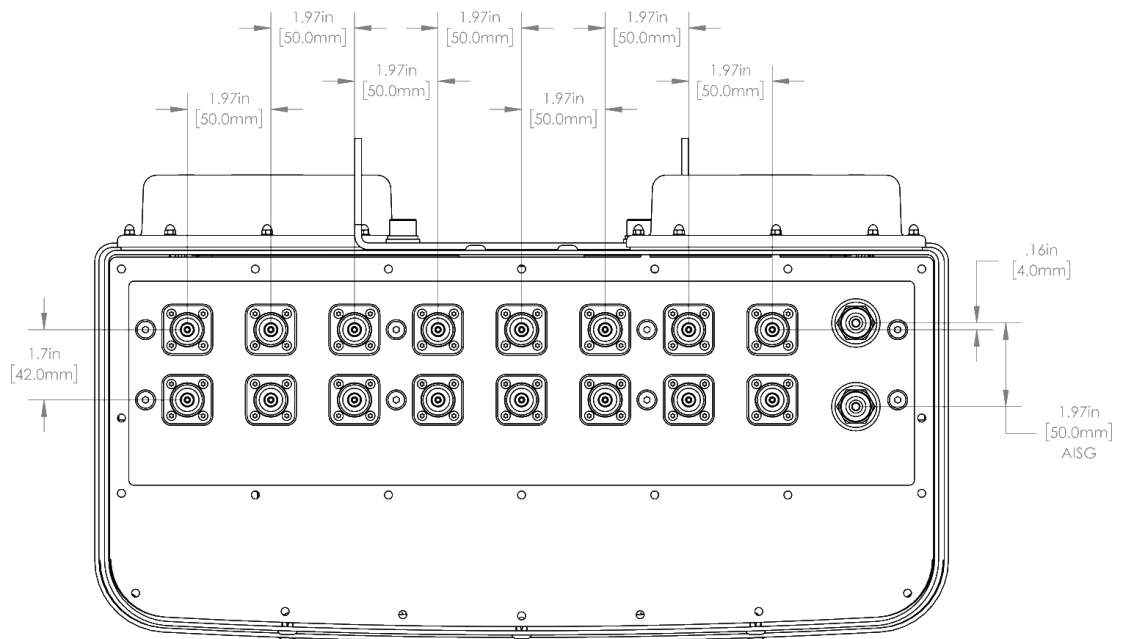



Antennas

Hybrid Bi-Sector™ Array

16HBSAR-BWW7NA

SPECIFICATIONS

Mechanical

RET to Array Configuration

Top of antenna Viewed from rear

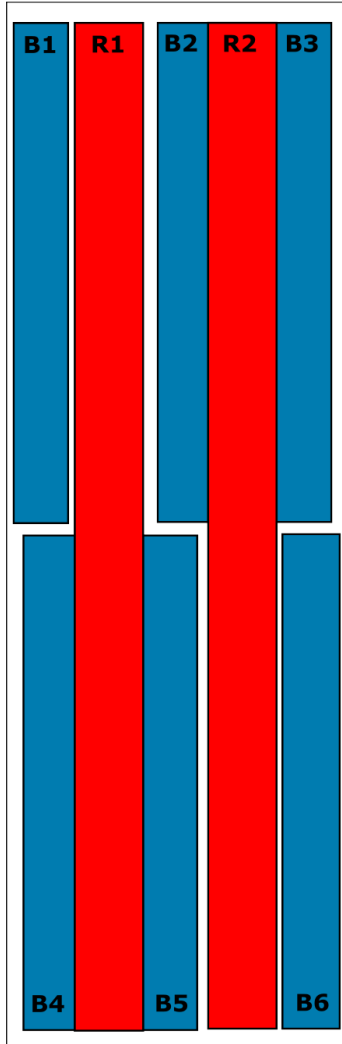

RET placement as view from rear of antenna

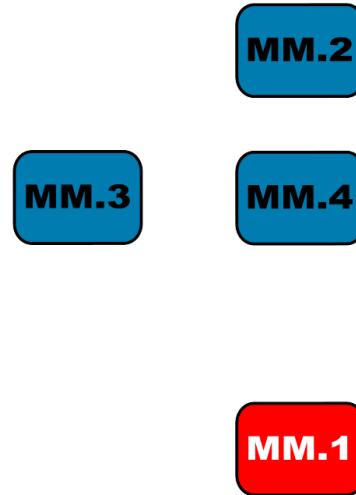

Array	Ports	Freq (MHz)	Ports controlled by common RET	AISG RET UID
R1	1, 2	698-896	1, 2, 3, 4	C1xxxxxxxMM.1
R2	3, 4	698-896		
B1	5, 6	1695-2180	5, 6, 7, 8	C1xxxxxxxMM.2
B6	7, 8	1695-2180		
B2	9, 10	1695-2180	9, 10, 11, 12 Left Beams	C1xxxxxxxMM.3
B4	11, 12	1695-2180		
B3	13, 14	1695-2180	13, 14, 15, 16 Right Beams	C1xxxxxxxMM.4
B5	15, 16	1695-2180		



Antennas

SPECIFICATIONS

Hybrid Bi-Sector™ Array

16HBSAR-BWW7NA

Typical Antenna Patterns

For detailed information on additional antenna patterns, contact customer support at support@cciproducts.com

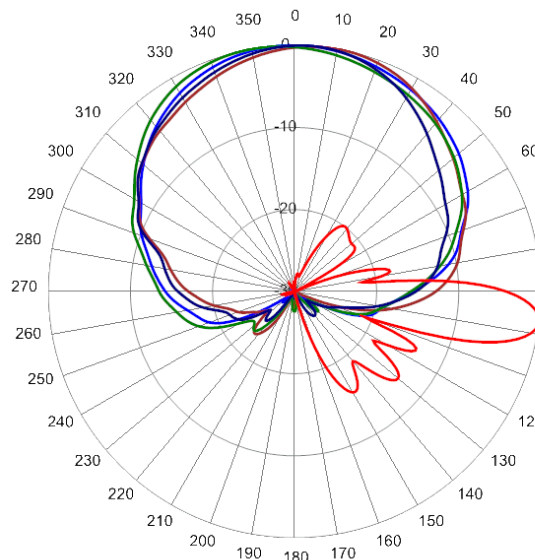

698 MHz Azimuth with Elevation 7°

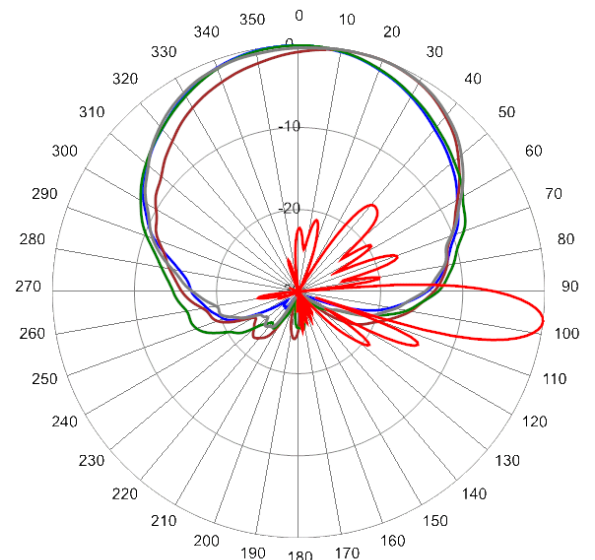

750 MHz Azimuth with Elevation 7°

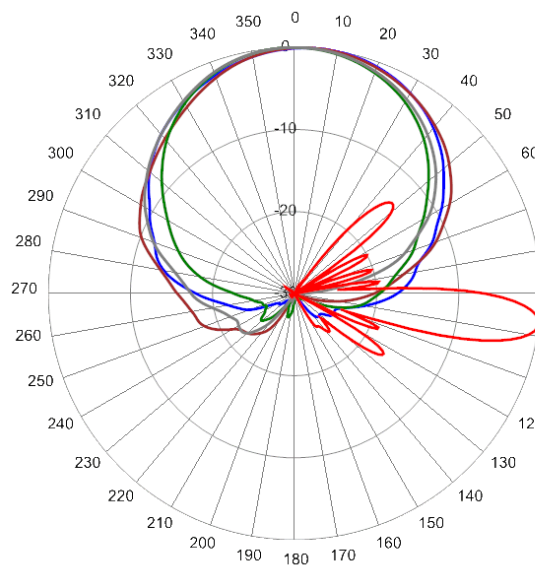

824 MHz Azimuth with Elevation 7°

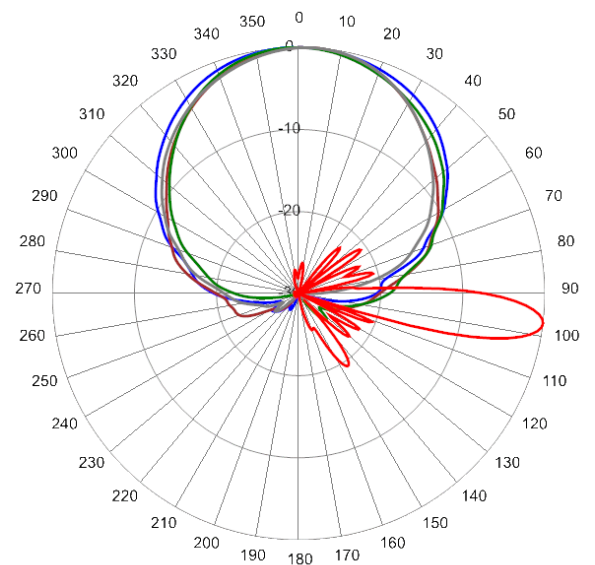

880 MHz Azimuth with Elevation 7°



Antennas

SPECIFICATIONS

Hybrid Bi-Sector™ Array

16HBSAR-BWW7NA

Typical Antenna Patterns

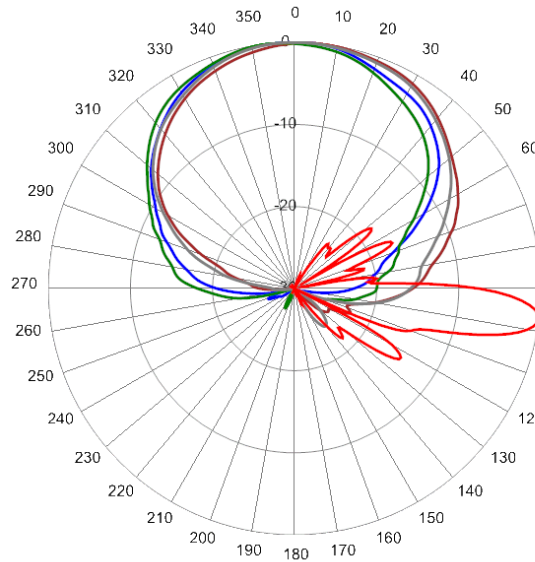

1695 MHz Azimuth with Elevation 7°

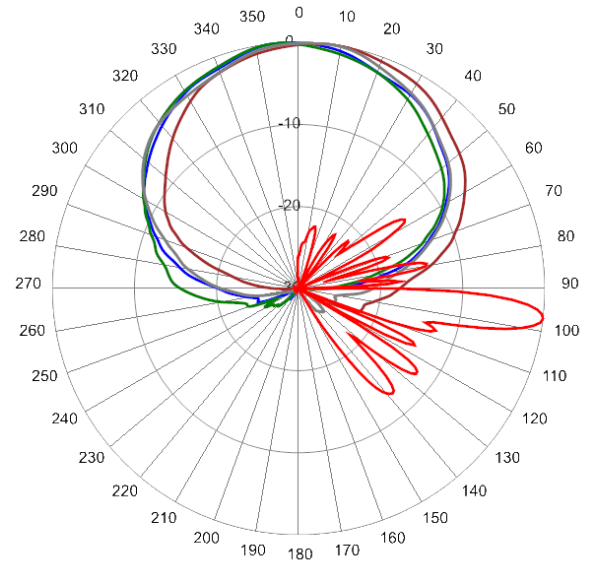

2170 MHz Azimuth with Elevation 7°

Typical Antenna Patterns

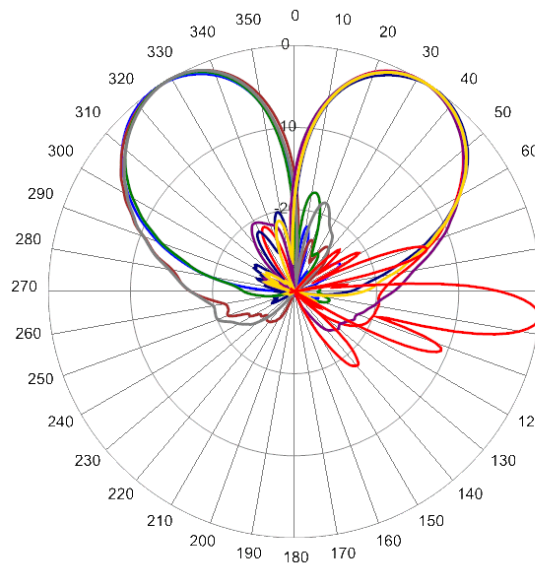

1825 MHz Azimuth with Elevation 6°

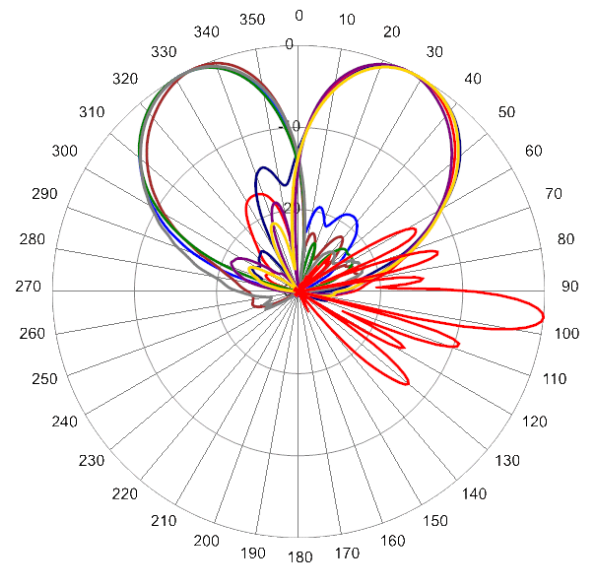

2170 MHz Azimuth with Elevation 6°



Antennas

ORDERING

Hybrid Bi-Sector™ Array

16HBSAR-BWW7NA

Parts & Accessories

16HBSAR-BWW7NAA-K	Seven foot (2.1 m) Hybrid Bi-Sector™ Antenna Array with 4.3-10 female connectors, 4 factory installed external BSA-RET400 RET actuators (Type 17 Internal) and MBK-01 mounting brackets
MBK-01	MBK-01 Mounting Kit with 0° - 10° mechanical tilt
MBK-16	MBK-16 Mounting Kit with fixed 0° mechanical tilt
BSA-RET400	Type 17 remote electrical tilt actuator
AISGC-M-F-10FT	10 Ft (3 m) Male/Female RRU to Antenna AISG cable



Antennas

ACCESSORIES

Mounting Bracket Kit

MBK-01

Mechanical

Weight	12.6 lbs (5.7 kg)
Hinge Pitch	47.25 in (1200 mm)
Mounting Pole Dimension	2 to 5 in (5 to 12 cm)
Fastener Size	M12
Installation Torque	40 ft·lb (54 N·m)
Mechanical Tilt Adjustment	0° - 10°

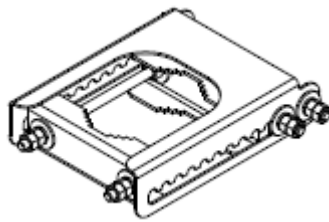

MBK-01 Top Adjustable Bracket

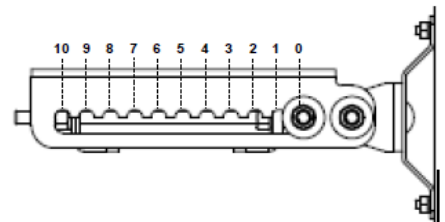

MBK-01 Top Adjustable Bracket Side View

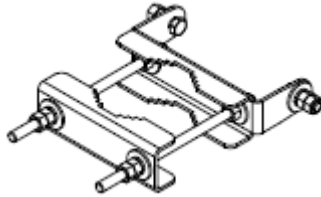

MBK-01 Bottom Fixed Bracket



Antennas

ACCESSORIES

Mounting Bracket Kit

MBK-16

Mechanical

Weight	9.9 lbs (4.5 kg)
Hinge Pitch	47.25 in (1200 mm)
Mounting Pole Dimension	2 to 5 in (5 to 12 cm)
Fastener Size	M12
Installation Torque	40 ft·lbs (54 N·m)
Mechanical Tilt	0°

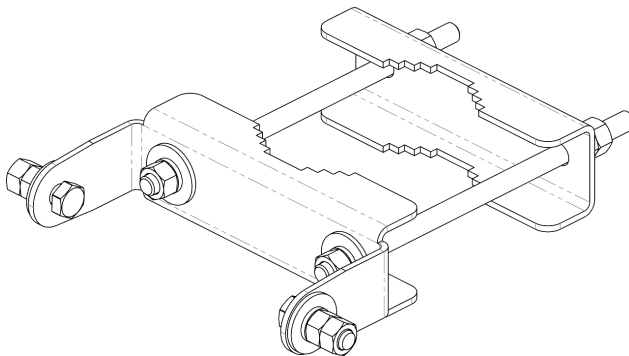
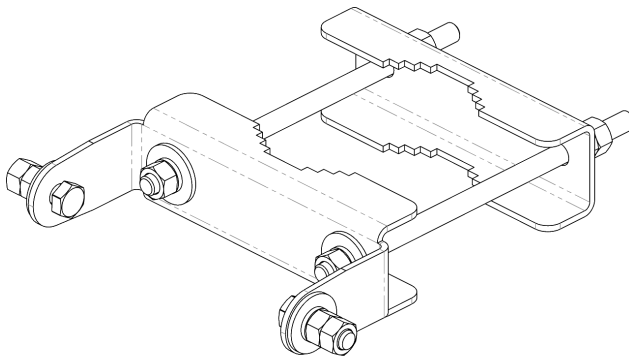

MBK-16 Top and Bottom Bracket



Antennas

ACCESSORIES

Internal Remote Electrical Tilt (iRET)

BSA-RET400

General Specifications

Part Number	BSA-RET400
Protocols	AISG 2.0
RET Type	Type 17
Adjustment Cycles	>10,000 cycles
Tilt Accuracy	±0.1°
Temperature Range	-40° C to 70° C

Electrical

Data Interface Signal	DC
Input Voltage	10-30 Vdc
Current Consumption Tilt	100 mA at $V_{in}=24$ (500 mA MAX)
Current Consumption Idle	10 mA at $V_{in}=24$

Mechanical

Dimensions (LxWxD)	7.0x5.3x1.8 in. (179x134x45 mm)
Housing	ASA/ABS/Aluminum
Weight	1.3 lbs (0.6 kg)

ASA= Acrylic Styrene Acrylonitrile
ABS=Acrylonitrile Butadiene Styrene

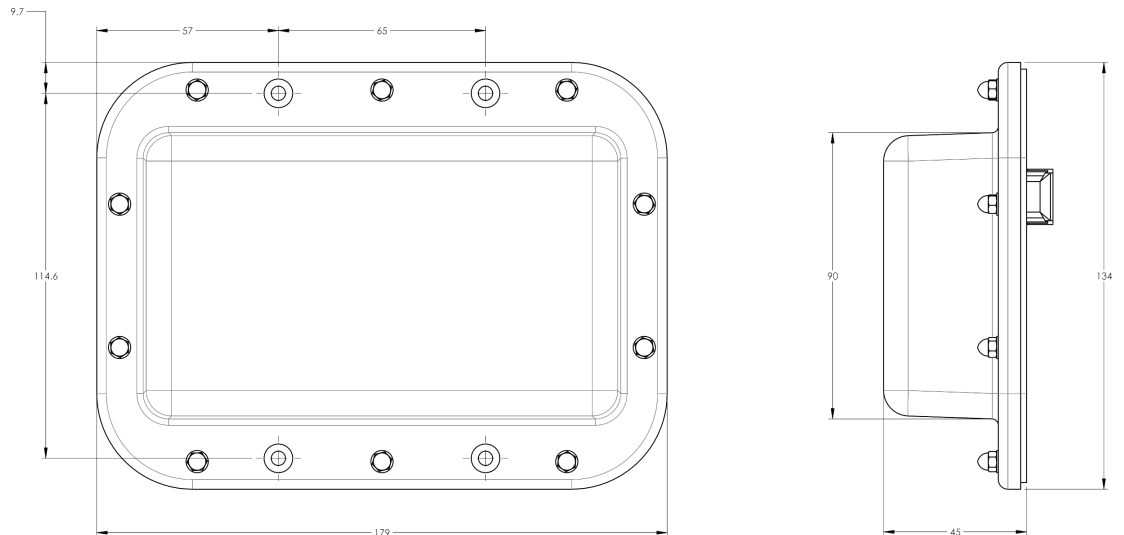



Antennas

ACCESSORIES

AISG Cable

AISGC-M-F-xFT

Electrical Specifications

Individual Cable Part Number	AISGC-M-F-x(FT)
Cable style	UL2464
Protocol	AISG 1.1 and AISG 2.0
Maximum voltage	300 V
Rated current	5 A at 104° F (40° C)

Mechanical Specifications

Individual Cable Part Number	AISGC-M-F-x(FT)
Cables per kit	1
Connectors	2 x 8 pin IEC 60130-9 Straight male/straight female
Tightening torque	Hand tighten only \approx 1.84 ft-lbs (2.5 Nm)
Construction	Shielded (Tinned Copper Braid)
Braid coverage	85%
Jacket Material	Matte Polyurethane (Black)
Conductors	1 twisted pair - 24 AWG 3 conductors - 19 AWG AWM style 2464
Cable Diameter	0.307 in (7.8 mm)
Length	See order details
Minimum bend radius	3.15 in (80 mm)

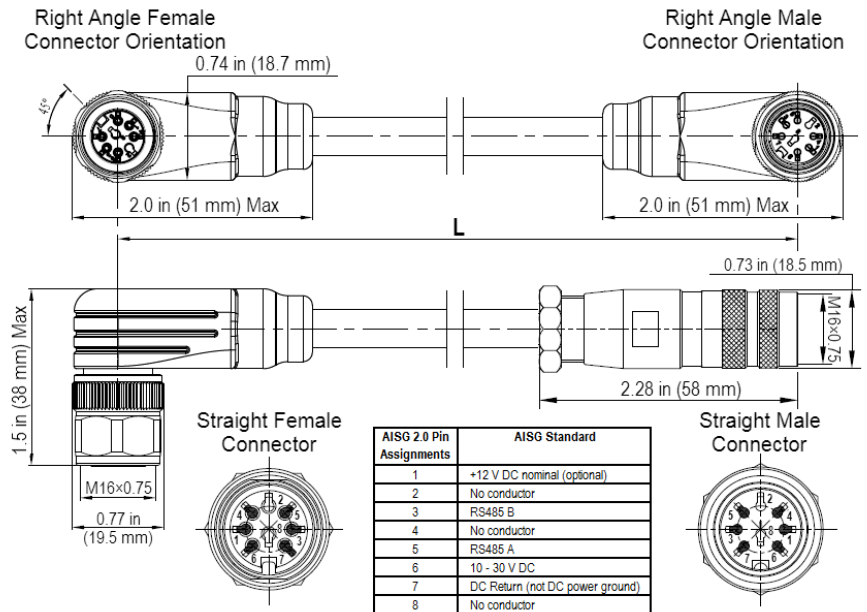

AISG-Male to AISG-Female Jumper Cable



Antennas

ACCESSORIES

AISG Cable

AISGC-M-F-xFT

Environmental Specifications

Individual Cable Part Number	AISGC-M-F-xFT
Temperature Range	-40° to 80° C
Flammability	UL 1581 VW-1
Ingress Protection	IEC 60529:2001, IP67



Antennas

STANDARDS & CERTIFICATIONS

Hybrid Bi-Sector™ Array

16HBSAR-BWW7NA

Standards & Compliance

Safety	EN 60950-1, UL 60950-1
Emission	EN 55022
Immunity	EN 55024
Environmental	IEC 60068-2-1, IEC 60068-2-2, IEC 60068-2-5, IEC 60068-2-6, IEC-60068-2-11, IEC 60068-2-14, IEC 60068-2-18, IEC 60068-2-27, IEC 60068-2-29, IEC 60068-02-30, IEC 60068-2-52, IEC 60068-2-64, GR-63-CORE 4.3.1, EN 60529, IP 24

Certifications

Antenna Interface Standards Group (AISG), Federal Communication Commission (FCC) Part 15 Class B, CE, CSA US, ISO 9001



CCI Communication Components Inc.
EXTENDING WIRELESS PERFORMANCE